

MODEL 906

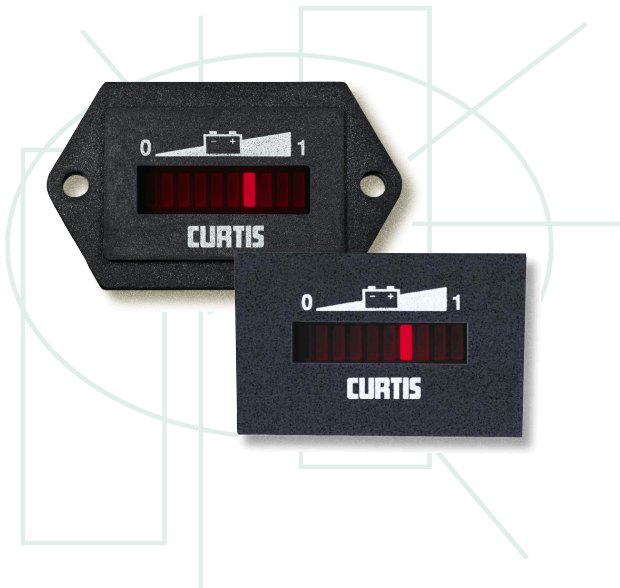

DESCRIPTION

Model 906 is an inexpensive, one piece, easy to install battery fuel gauge. It is completely solid state and provides a reliable, accurate, and easy to read display of battery state-of-charge. Model 906 is available in five panel mount packages and a printed circuit board mounted module for custom dash panel applications.

APPLICATION

This battery fuel gauge features Curtis-patented technology and is ideal for golf cars, commercial cleaning equipment, mobility aids, electric bicycles, electric marine motors, medical devices, and similar equipment.

FEATURES

- All principal circuits are integrated in a single chip for long-life reliability.
- A 10-bar LED displays the state of charge successively, bar by bar, from full to empty.
- At 70% depth of discharge, a flashing LED signals an "energy reserve" alert.
- At 80%, alternately flashing LEDs provides an "empty" status warning.
- Model 906 is compact and easily installed in panel cutouts of only 36.8 X 24.1 mm, with less than 35 mm behind panel clearance needed.
- Recognizes improperly charged battery.
- Keyswitch activated LED display (state-of-charge is monitored as long as 906 is connected to battery).
- Two reset methods: Open Circuit Reset-OCR Upon reconnection of a battery the gauge will reset if it measures 2.09 volts/cell or higher. High Voltage Reset-HVR Gauge must measure 2.35 volts per cell for 6 continuous minutes during charging.

OPTIONS

- The Output Signal option causes the voltage on pin 3 to drop from 5 to 0 volts at 80% discharge. It can be used to signal another component or to allow for the disabling of a specified vehicle function, insuring against abusive deep discharge conditions. The Output Signal can also be used to drive the Curtis 1178 Relay Module.
- An external memory module can be installed to recall state-of-charge whenever the vehicle battery is disconnected. Requires an external battery module, Curtis model number 1177, sold separately. (Note: Output option and memory module cannot be combined.)
- Special models and custom panels are available -please contact your Curtis sales representative.

SPECIFICATIONS

System Voltages: 12V, 24V, 36V, 48V

Operating voltage: +/-25% of nominal voltage

Operating temperature: -40°C to +85°C

Storage temperature: -50°C to +90°C

Shock & Vibration: Meets SAE J 1378

CURTIS INSTRUMENTS, INC.
200 KISCO AVENUE
MT. KISCO, NY 10549 USA
TEL (914) 666-2971
FAX (914) 666-2188

CURTIS INSTRUMENTS, (UK) LTD.
5 UPPER PRIORY STREET
NORTHAMPTON NN1 2PT, ENGLAND
TEL 44 (0) 1604-629755
FAX 44 (0) 1604-629876

**CURTIS INSTRUMENTS INDIA
PRIVATE LTD.**
1199, GHOLE ROAD
PUNE 411004, INDIA
TEL 91 (0) 20-5531288
FAX 91 (0) 20-5539192

MODEL 906

CASE STYLES/DIMENSIONS: mm

F Case

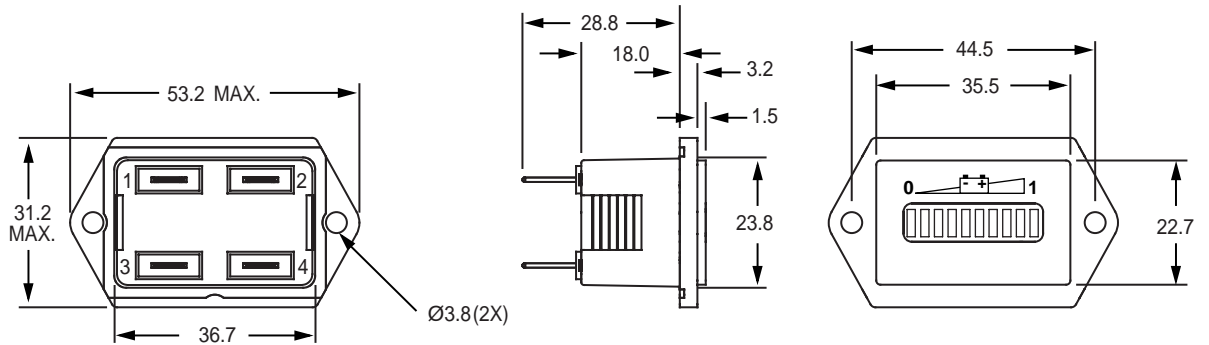

J Case

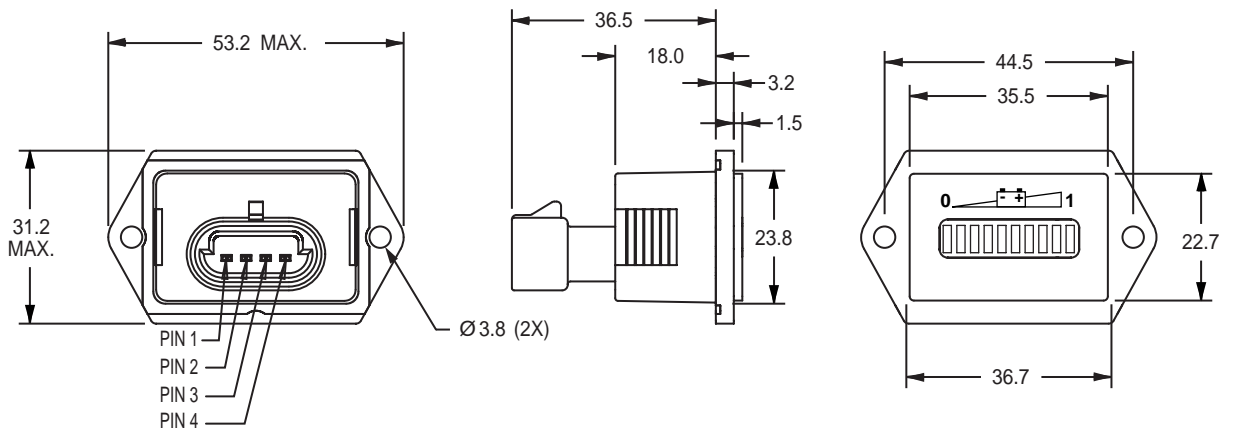

D Case

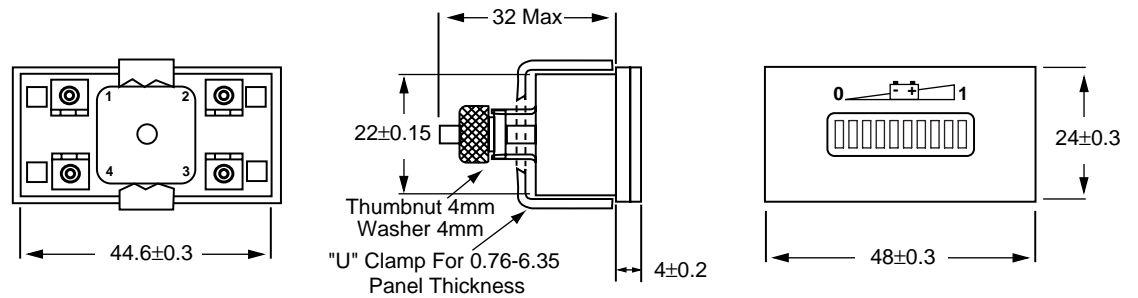

Y Case

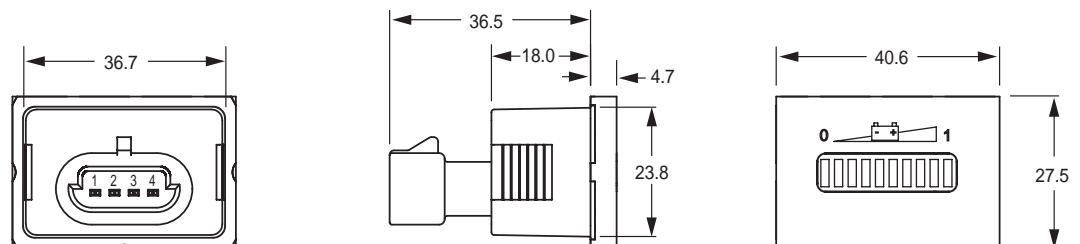

MODEL 906

CASE STYLES/DIMENSIONS: mm

Z Case

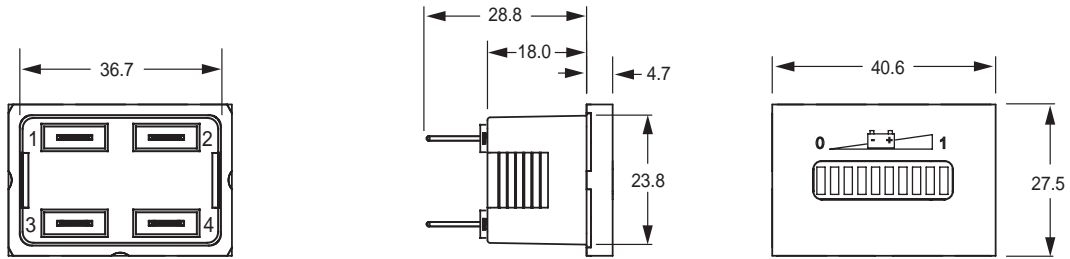

P Module

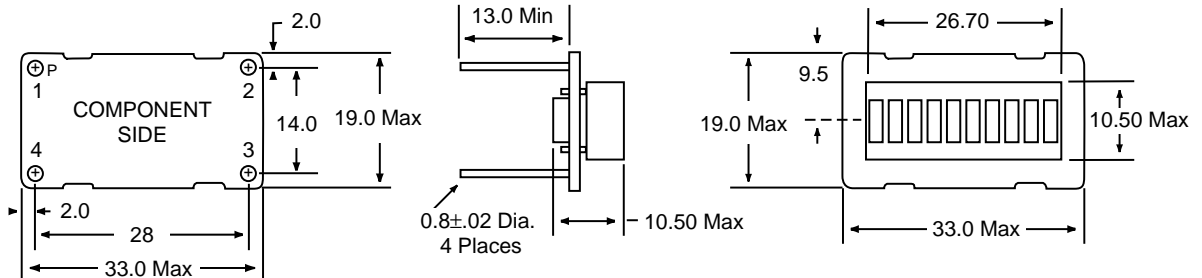

Note: The 906 modules are supplied with critical components exposed. The user must encase the module to provide adequate protection, depending upon the user's applications and conditions. For proper mechanical support, all four pins should be soldered to the PC Board.

Terminals:

- 1 - Battery +
- 2 - Battery -
- 3 - Output Signal or Memory Battery (positive)
- 4 - Key Switch

Lens Material: Glass or Plastic

Case Material: ABS KJW, Black

MODEL ENCODEMENT

906	F	24	H	N	A	A	O
Case Styles	F J D Y Z P	Voltage 12V 24V 36V 48V	Reset Level H=2.35 V/cell HVR (no memory) B=2.09 V/cell OCR (with memory)	Discharge Profile N=2.04 V/cell @ full to 1.73 V/cell @ empty [G=1.97 V/cell @ full to 1.75 V/cell @ empty] [W=2.02 V/cell @ full to 1.85 V/cell @ empty]	Option A=No option D=Output signal 5 ± 0.5V above empty 0 to 0.1 V at empty 10K Ω impedance M=Memory option		Artwork O=Standard Curtis

Note: Items designated in brackets [] are not standard production. Contact factory.

This gage is not intended to measure the state of charge of batteries subject to extended periods of inactivity since it does not account for self-discharge effects. Consult factory for details.

WARRANTY Two year limited warranty from time of delivery.